

ENGINEERING STANDARDS

Rosedale Products, Inc.
3730 West Liberty Road
Ann Arbor, MI 48103

IOM
D8150STD.WP6
n:\iom\



Issue Date: 21JUN96
Revision:
Revision Date:

Specification No.
7.4.10
PAGE: 1 of 6

INSTALLATION, OPERATION, & MAINTENANCE MANUAL

INSTALLATION, OPERATION AND MAINTENANCE MANUAL

ROSEDALE PRODUCTS, INC.



DUPLEX MODEL 8

150 PSIG RATED FILTER UNIT

Table of Contents

I.	Installation	2
II.	Operation	3
III.	Spare Parts List	4
IV.	Spare Parts Diagram	5

ENGINEERING STANDARDS

Rosedale Products, Inc.
3730 West Liberty Road
Ann Arbor, MI 48103

IOM
D8150STD.WP6
n:\iom\



Issue Date: 21JUN96
Revision:
Revision Date:

Specification No.
7.4.10
PAGE: 2 of 6

INSTALLATION, OPERATION, & MAINTENANCE MANUAL

I. Installation

Please remove all shipping and crating materials carefully. Be sure to remove the plugs from the inlet and outlet openings. Dispose of all crating materials safely.

After positioning the Model 8 Duplex Filter unit in its proper location, secure the adjustable tripod leg assemblies to the floor or platform. (Some installations may not require the adjustable tripod leg assemblies.)

The duplex system is normally supplied with the inlet-outlet connections in a horizontal orientation (facing in opposite directions) as shown on the last page of this manual. However, the inlet-outlet orientations can be varied depending on your application.

The inlet service line should be connected to the inlet flange or NPT coupling located near the top of the units (above basket level).

The outlet service line should be connected to the outlet flange or NPT coupling, located near the middle or bottom of the units (below basket level).

There are two 1/4" NPT ports, one on the inlet tee and one on the outlet tee, of the Model 8 Duplex Filter unit. Additionally, there is one 1/4" NPT port in each cover of the Model 8 Duplex Filter unit. These ports can remain plugged or used for pressure gauges, or special fittings as your application requires.

Some installations require electrical grounding of all equipment, be sure to provide adequate grounding where necessary.

After completing installation be sure to double check connections for integrity. Your Model 8 Duplex Filter unit has been factory pressure tested leak free, therefore, any seepage problems usually occur from improper installation connections.

You are now ready to install the filter baskets and bags. (Your Rosedale Model 8 Duplex Filter unit consists of two Rosedale Model 8 Filter units. They are designed for continual flow through one unit while servicing the other). Remove cover by loosening the cover eye nuts on one of the filters. The eye nuts in the slotted corners should be loosened sufficiently to swing free. Loosen the third eye nut sufficiently to allow the top cover and closure assembly to swing away from the top of the unit.

If your application requires a basket seal, insert the basket seal into the collar groove. Refer to Figure 1 or Figure 2 in the Spare Parts Diagram for installation position of your seal.

Place the basket into the filter housing, make sure the basket flange is firmly seated on top of the basket collar.

Insert bag into the bag basket making sure filter bag ring is firmly seated into the basket collar. For best results, be sure filter bag is installed fully extended to the bottom of the basket.

Before replacing cover assembly, inspect cover seal gasket (replacing as necessary). Close cover and alternately tighten the three clamp assemblies evenly to ensure a leak proof seal between the cover and housing body. The recommended torque value for 5/8"-11 closure assemblies is 150^{ft}-lbs. Repeat the above steps for installing the filter basket and bag for the other unit.

ENGINEERING STANDARDS

Rosedale Products, Inc.
3730 West Liberty Road
Ann Arbor, MI 48103

IOM
D8150STD.WP6
n:\iom\



Issue Date: 21JUN96
Revision:
Revision Date:

Specification No.
7.4.10
PAGE: 3 of 6

INSTALLATION, OPERATION, & MAINTENANCE MANUAL

Your Rosedale Model 8 Duplex Filter unit is now ready for operation!

ENGINEERING STANDARDS

Rosedale Products, Inc.
3730 West Liberty Road
Ann Arbor, MI 48103

IOM
D8150STD.WP6
n:\iom\



Issue Date: 21JUN96
Revision:
Revision Date:

Specification No.
7.4.10
PAGE: 4 of 6

INSTALLATION, OPERATION, & MAINTENANCE MANUAL

II. Operation

Filter System Start-Up Procedure:

Prior to turning on the flow to the inlet service, please make the following checks:

1. Check inside filter unit to be sure basket and filter bag (if applicable) are in housing and do not require cleaning or replacement. If necessary install a clean filter basket and bag (if applicable).
2. Check that filter unit cover is securely fastened to housing. You are now ready to open the flow to the inlet service line. Slowly open the inlet service line approximately 25% of normal operational flow (open slowly as not to displace filter bag inside the housing). After filter unit is pressurized and vented, slowly open outlet service line unit valve until completely open. Complete opening of inlet service line until desired flow rate is reached.

Once the desired service flow has been established, the filter will operate efficiently until dirty. However, under no circumstances should more than *15 PSI Differential Pressure* through the filter be obtained. Operating the filter unit with a high differential may cause filter bags to rupture and/or cause damage to filter system and downstream equipment.

To prevent excessive drop through the filter unit, regular inspection of the filter media is required. Monitoring of differential pressure through the housing can be utilized as a means of determining whether or not the filter media needs cleaning or replacement.

Filter Media Cleaning/Replacement Procedure (Side of duplex not in service):

The duplex system features continuous filtering capabilities. When it becomes necessary to clean or replace filter media during continuous operating conditions, follow the procedure outlined below:

1. Open balancing valve, if applicable, to equalize pressure in both housings.
2. Unlock mechanical valve actuator assembly by removing the lynch pin.
3. *Slowly* move the mechanical actuator lever 90E to divert the flow to the clean filter vessel.
4. Replace lynch pin to prevent accidental switching of fluid flow to filter being serviced.
5. Close balancing valve, if applicable.
6. Relieve the pressure from the filter vessel being serviced.

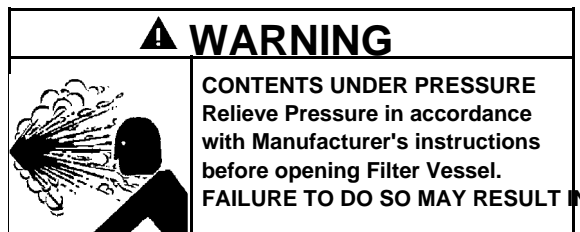

7. Drain housing sufficiently to access filter basket.
8. Remove cover by loosening the cover eye nuts. The eye nuts in the slotted corners should be

ENGINEERING STANDARDS

Rosedale Products, Inc.
3730 West Liberty Road
Ann Arbor, MI 48103

IOM
D8150STD.WP6
n:viom\



Issue Date: 21JUN96
Revision:
Revision Date:

Specification No.
7.4.10
PAGE: 6 of 6

INSTALLATION, OPERATION, & MAINTENANCE MANUAL

IV. Spare Parts Diagram

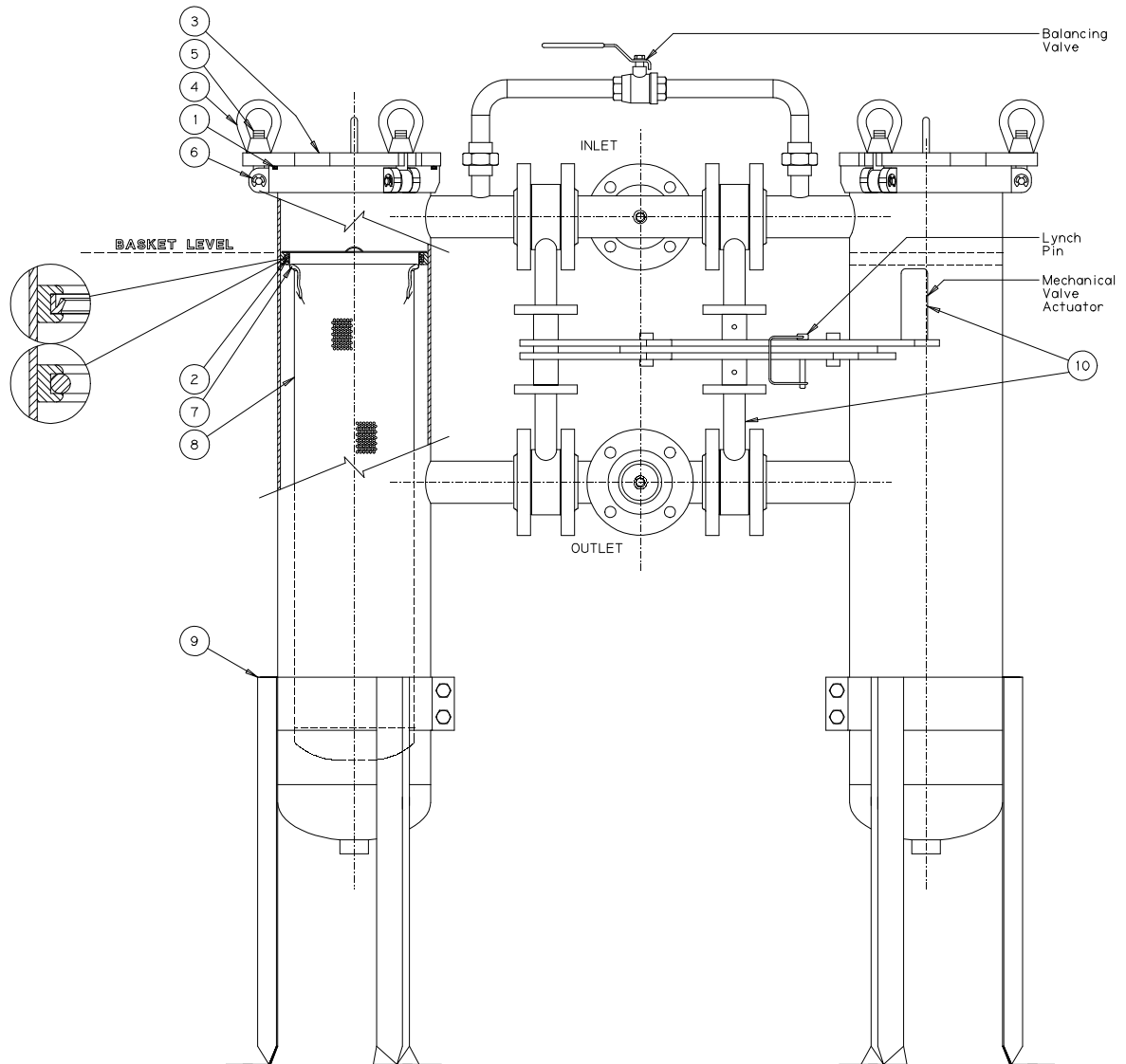

ENGINEERING STANDARDS

Rosedale Products, Inc.
3730 West Liberty Road
Ann Arbor, MI 48103

IOM
D8150STD.WP6
n:\iom\



Issue Date: 21JUN96
Revision:
Revision Date:

Specification No.
7.4.10
PAGE: 7 of 6

INSTALLATION, OPERATION, & MAINTENANCE MANUAL

Important Notice

Warranty: In the event any Rosedale Products, Inc. filtration product is found to be defective in material, workmanship, or not in conformance with any express warranty for a specific purpose, Rosedale's only obligation and your exclusive remedy, shall be to repair, replace or refund the purchase price of such parts or products upon timely notification thereof and substantiation that the product has been stored, maintained and used in accordance with Rosedale's written instructions.

EXCLUSIONS TO WARRANTY: THIS WARRANTY IS EXCLUSIVE AND IS IN LIEU OF ANY IMPLIED WARRANTY OF MERCHANTABILITY, FITNESS FOR A PARTICULAR PURPOSE OR OTHER WARRANTY OF QUALITY, EXCEPT OF TITLE AND AGAINST PATENT INFRINGEMENT.

LIMITATION OF LIABILITY: Except as provided above, Rosedale shall not be liable or responsible for any loss or damage, whether direct, indirect, incidental, special or consequential, arising out of sale, use or misuse of Rosedale filtration products, or the user's inability to use such products.

THE REMEDIES SET FORTH HEREIN ARE EXCLUSIVE.

Rosedale Products, Inc.
3730 West Liberty Road
Ann Arbor, MI 48103 USA
313-665-8201
800-821-5373
Fax. 313-665-2214
Filters@mcimail.com
<http://www.webcom.com/~filters/>

ENGINEERING STANDARDS

Rosedale Products, Inc.
3730 West Liberty Road
Ann Arbor, MI 48103

IOM
D8150STD.WP6
n:\iom\



Issue Date: 21JUN96
Revision:
Revision Date:

Specification No.
7.4.10
PAGE: 8 of 6

INSTALLATION, OPERATION, & MAINTENANCE MANUAL