



Product sheet

Servo Gauge 854XTG



The superior alternative for float and other low cost level gauges

Benefits

Easy to install

Enraf offers the 854XTG servo gauge as a superior alternative to mechanical float and tape gauges or other low cost level measuring devices.

The instrument provides the superior servo gauge technology.

Proven technology

The 854XTG servo gauge offers the proven accuracies and performances of the Advanced Technology Gauge (854ATG).

Low commissioning costs

The option slot for additional features allows the connection of temperature measuring elements for spot- and average product temperature, as well as for product temperature profiles.

Simple interfacing

Multi-functional

The standard Enraf field-proven two-wire fieldbus is utilized for connection to remote indicators, tank inventory systems as well as host systems.

The 854XTG can also be provided with standard Modbus output or 4-20 mA level output for direct connection to control systems and other indicators with an analog input.

The instrument can be configured and monitored via the Portable Enraf Terminal (PET) connected to the optical infra-red port, without interfering with central systems operation. Automatic correction of tank deformation, roof movement, drum deviation, wire weight and displacer size etc. are included as standard in this instrument.



In case of heavy turbulence, the wave integration feature provides stable operation.

The 854XTG servo gauge has a 2" mounting flange.

Measuring specifications

Measuring range	: Standard 0 - 27 m (0 - 88 ft) Optional 0 - 37 m (0 - 121 ft) 0 - 35 m (0 - 115 ft) (with measuring wire up to 150 m (492 ft))
Measuring accuracy level	: ± 1 mm (± 0.04 ") ¹⁾
Measuring accuracy interface	: ± 2 mm (± 0.08 ") ²⁾
Measuring accuracy density	: ± 5 kg/m ³ (± 0.31 lb/ft ³) ³⁾
Measuring accuracy temp.	: ± 0.1 °C (± 0.18 °F) ^{1) 4)}
Sensitivity	: ± 0.1 mm (± 0.004 ") ¹⁾
Repeatability	: ± 0.1 mm (± 0.004 ") ¹⁾
Wave integration time	: Programmable, three setpoints, between 0.5 s and 10 s

Mechanical

Flange	: 2" 150 lbs ff acc. to ANSI B16.5, finish: turning, Ra = 3.2 µm - 12.5 µm compatible with DN50, PN20, ff, acc. to ISO 7005-1
Dimensions	: See back page
Weight	: 16 kg (35 lb)
Cable entries	: 4 pcs ¾" NPT threaded

Environmental

Operating pressure	: Up to 6 bar / 0.6 MPa (90 psi)
Ambient temperature	: -40 °C to +65 °C (-40 °F to +149 °F)
Protection class	: IP 65 according to EN 60529 (NEMA 4)
Safety	: Explosion proof - II 1/2 G EEx d IIB T6 or EEx d [ia/ib] IIB T6 according to ATEX - Class I, Division 1, Groups B, C and D, in acc. to ANSI / NFPA 70 (FM, USA)

Materials

Housing	: Cast aluminum Int. reg. AA A356 EN AC-AISI7Mg0,3 EN1706
Finish	: Chromatinized according to MIL-C-5541C
Measuring drum, drum shaft	: Stainless steel (1.4401) EN10088 @ AISI 316
Measuring wire	: See 'Identification code', Pos 12
O-rings	: Drum cover Silicone / FEP (others NBR 70)

Electrical

Power supply	: 110/130/220 V (+10% to -20%) and 230 V ($\pm 15\%$), optional 65 V (+10% to -20%), also suitable for 240 V (+10% to -20%)
Frequency variations	: 50 Hz to 60 Hz ($\pm 10\%$)
Power rating	: 25 VA, $I_{max} = 2$ A

Transmission

Type	: Serial, ASCII coded, Bi-Phase Mark modulated (BPM)
Isolating voltage	: > 1,500 V
Lightning protection	: Full galvanic separation via isolating transformers
Protocol	: Standard Enraf fieldbus (GPU protocol)
Common mode rejection	: > 150 dB
Cabling	: Two conductors, twisted pair, $R_{max} = 200 \Omega / \text{line}$, $C_{max} = 1 \mu\text{F}$
Transmission to	
Portable Enraf Terminal (PET)	: Infra-red, serial

Options

Alarm relay outputs	: 2x SPDT, galvanically isolated, $V_{max} = 50$ Vac or 75 Vdc, $I_{max} = 3$ A
Density measurement	: See 'Identification code', Pos 15 (with density displacer)
Analog level output	: 4 - 20 mA (accuracy $\pm 0.1\%$ full scale)
Input boards	: Spot RTD, VITO probes for average temperature and/or water measurement, HART® devices
Data transmission	: Standard Modbus via RS-232C or RS-485 i.s. transmission for Tank Side Indicator (TSI)
Cable entries	: Adapters available to fit other sizes cable glands

HART® is a trademark of the HART Communications Foundation.

¹⁾ Under reference conditions

²⁾ Difference product density 100 kg/m³ (6.25 lb/ft³)

³⁾ (optional) with a density displacer and calibrated for density measurement

⁴⁾ With VITO temperature probe

Identification code

Pos 1 Application																	
U	General purpose																
X	W&M certified																
Pos 2 Data transmission																	
E	Enraf Bi-phase mark protocol (standard)																
I	i.s. Output for Tank Side Indicator (TSI) and Enraf Bi-Phase Mark (BPM) protocol																
R	RS-232C GPU protocol (only when Pos 4 = B, C, G, J, M, U or Z)																
S	RS-485 GPU protocol (only when Pos 4 = B, C, G, J, M, U or Z)																
V	RS-232C standard Modbus (only when Pos 4 = B, C, G, J, M, U or Z)																
W	RS-485 standard Modbus (only when Pos 4 = B, C, G, J, M, U or Z)																
Pos 3 Display																	
B	Without display																
Pos 4 I/O options																	
B	Spot temperature Pt100																
C	VITO temperature and/or water probe																
G	Average temperature MIT interface + HART device(s)																
J	VITO temperature and/or water probe + HART device(s)																
M	Average temperature MIR interface																
N	Average temperature MIR interface + Analog level output																
U	Spot temperature Pt100 + HART device(s) (not possible when Pos 2 = I)																
V	Analog level output																
W	Analog level output + VITO temperature and/or water probe																
X	Analog level output + VITO temperature probe																
Z	None																
Pos 5, 6, 7 Instrument designation																	
8	5	4	Servo gauge XTG														
Pos 8 Pressure version																	
B	Up to 6 bar 0.6 MPa (90 psi)																
Pos 9, 10 Drum compartment & flange																	
			mat. *)	flange	acc. to	finish	compatible with	acc. to									
2	1		Al	2" 150 lbs ff	ANSI B16.5	turning, Ra = 3.2 - 12.5 µm	DN50, PN20 ff	ISO 7005-1									
Pos 11 Safety approvals																	
A	ATEX		Europe		For other approvals please contact your nearest Enraf office												
F	FM		USA														
Pos 12 Measuring range & wire material																	
2	27 m (88 ft)		AISI 316		K	37 m (121 ft)		Hasteloy C22									
A	27 m (88 ft)		Hasteloy C22		L	37 m (121 ft)		Tantalum									
B	27 m (88 ft)		Tantalum		M	37 m (121 ft)		Invar									
C	27 m (88 ft)		Invar		N	37 m (121 ft)		Platinum / 20% Iridium									
D	27 m (88 ft)		Platinum / 20% Iridium		9	35 m (115 ft)		AISI 316									
3	37 m (121 ft)		AISI 316			with 150 m (492 ft) wire length											
Pos 13 Purge connection																	
*	Option not used																
Pos 14 Mains supply																	
A	220 V		50/60 Hz		R	130 V		50/60 Hz									
C	110 V		50/60 Hz		S	65 V		50/60 Hz									
K	230 V		50/60 Hz														
Pos 15 Density measurement																	
D	With servo density measurement				*	Option not used											
Pos 16 Alarms																	
W	With 2 programmable SPDT alarms				Z	No alarms											
U	E	B	Z	8	5	4	B	2	1	A	2	*	A	*	Z	Typical identification code	
		B		8	5	4	B	2	1			*					Your identification code

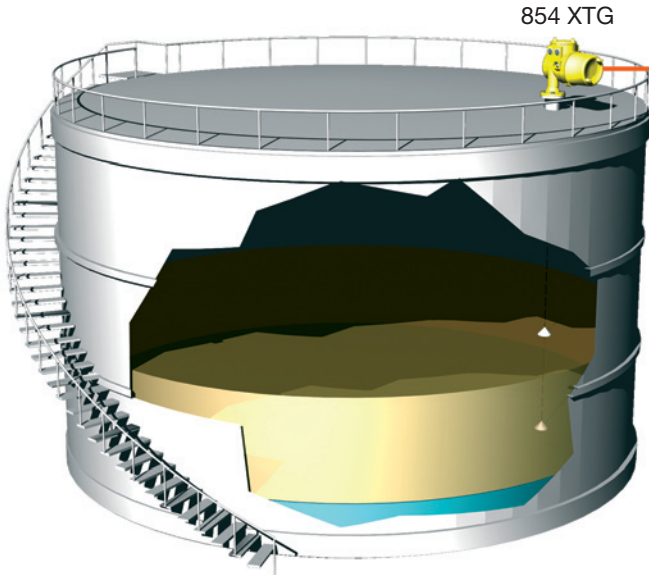
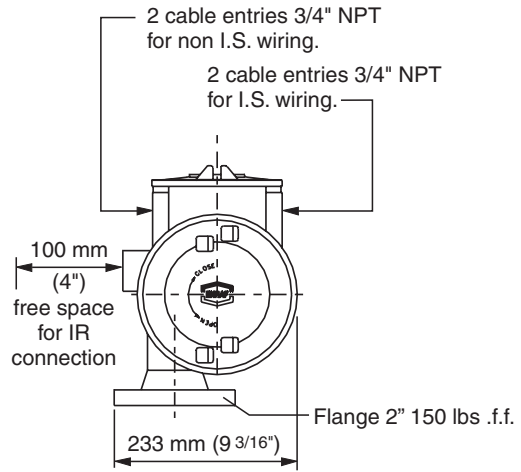
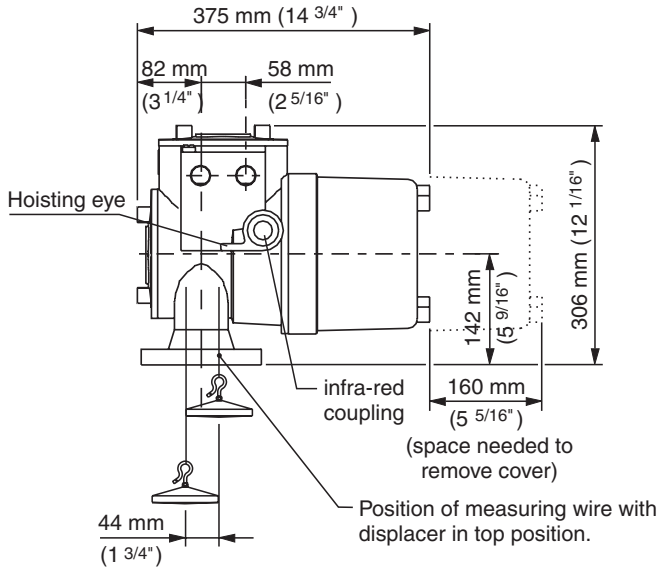

854 XTG

Cable specifications Serial transmission

Number of wires : 1 twisted pair (pref. shielded)
 Resistance : $R_{max} = 200 \Omega / \text{line}$
 Capacitance : $C_{max} = 1 \mu\text{F}$

Outputs

- Modbus
- 4-20 mA for level
- Two relay level alarms
- i.s. output for Tank Side Indicator (TSI)
- Digital transmission to
 - indicators
 - systems

Inputs

- HART® devices
- Spot temperature element
- VITO probes for average temp. and/or water bottom measurement

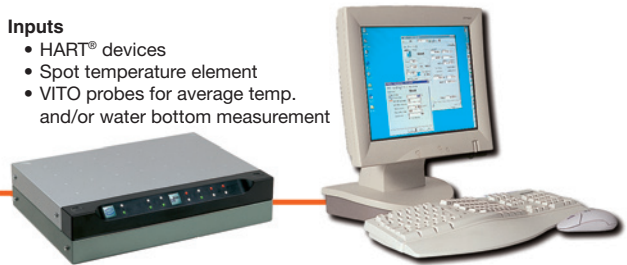

Field interface

Entis system

We at Enraf are committed to excellence.

Enraf B.V.
 Delftechpark 39, 2628 XJ Delft
 P.O. Box 812, 2600 AV Delft, The Netherlands
 Tel.: +31 (0)15 2701 100, Fax: +31 (0)15 2701 111
 Email: info@enraf.nl, http://www.enraf.com

China: Enraf B.V. (Shanghai Rep. Office)
 18G, International Shipping & Finance Center
 720 Pudong Avenue, Shanghai 200120
 Tel.: +86 21 50367000, Fax: +86 21 50367111

France: ENRAF S.a.r.l.
 ZAC les Beaudottes, 15 rue Paul Langevin
 93270 SEVRAN
 Tel.: +33 (0)1 49 36 20 80, Fax: +33 (0)1 43 85 26 48

Germany: Enraf GmbH
 Obere Darmstrasse 10, 42653 Solingen
 Postfach 101023, 42648 Solingen
 Tel.: +49 (0)212 58 750, Fax: +49 (0)212 58 7549

India: Enraf India Pvt. Ltd.
 A/311, Sagar Tech Plaza, Andheri - Kurla Road,
 Sakinaka, Andheri (E), Mumbai 400072
 Tel.: +91 22 28523990, Fax: +91 22 28522264

India: Enraf India Pvt. Ltd.
 BMD Business Centre, City Centre, 2nd floor,
 66/39, Thirumalai Pillai Road,
 T.NAGAR, Chennai-60017
 Tel.: +91 44 28156999, Fax: +91 44 28156888

Russia: Enraf B.V. (Moscow Rep. Office)
 21, Dostoevskogo street
 127 473 Moscow
 Tel. / Fax: +7 (0)95 788 0713, Tel. / Fax: +7 (0)95 788 0691

Singapore: Enraf Pte. Ltd.
 89 Science Park Drive, #03-06 Rutherford
 Singapore Science Park 1, Singapore 118261
 Tel.: +65 676 94 857, Fax: +65 683 67 496

United Kingdom: Enraf Ltd.
 4th Floor, Scottish Mutual House, 27/29 North Street
 Hornchurch, Essex RM11 1RS
 Tel.: +44 (0)1708 473 473, Fax: +44 (0)1708 471 042

USA: ENRAF Inc.
 4333 West Sam Houston Parkway North, Suite 190
 Houston, TX 77043
 Tel.: +1 832 467 3422, Fax: +1 832 467 3441

Information in this publication is subject to change without notice.

© Enraf is a registered trademark © Enraf B.V. The Netherlands

