

## Coolant Filter Selection Guide

For low pressure machine tool coolant applications

Rosedale Filtration Products has installed a wide variety of systems throughout the metalworking and manufacturing industries. Our high quality industrial filters prevent metal chips, fines and other debris from contaminating cutting oils and coolants. Our pre-selected systems include the housing, appropriate seals and a filter bag.

### General Requirements and Measurements

There are important factors that enter into specifying the level of coolant cleanliness that will improve the finish and extend tool life. Variables that affect coolants include: full or partial filtration, single pass or recirculating flow, dirt loading, pressure drop through all components of the filter systems, coolant temperature, flow rate, system pressure, and the presence of tramp oil.

This filtration guide is intended to provide general information about industry specifications. Use the data to compare and evaluate your specific application.

### Typical Applications

Our schematics illustrate how Rosedale filters can be easily installed in any coolant circuit. The versatile Rosedale filters can be used in all metalworking machines, including milling, boring, broaching, grinding, drilling, turning, etc.

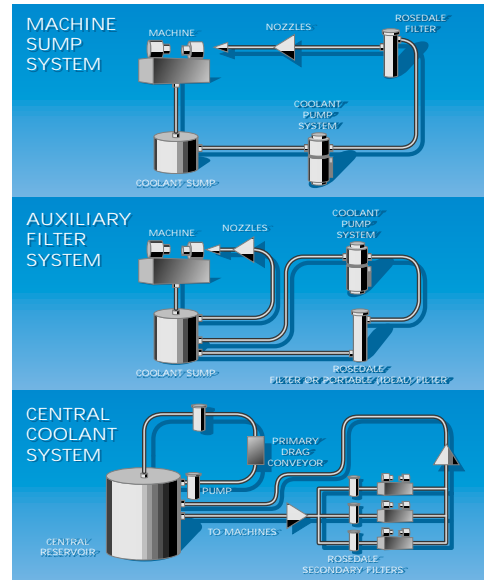

### Methodology

Charts, schematics and other information provided or referred to throughout this guide are intended as examples only. "Nominal" filter ratings are used and monthly throughputs are calculated to include the sizing of filter elements to provide a 30 day minimum life expectancy based on a typical dirt load ingestion.

Rosedale offers the widest range of filters and filter bags, including oil-adsorbing, high temperature, high-capacity bags, high-efficiency liquid filter bags, and Beta Bag® filter bags. The term Beta Ratio or Beta Rating refers to the number of particles upstream divided by the number of particles downstream in a given size. For example, if there are 100 five micron particles upstream and 50 five micron particles downstream of the filter bag, then the Beta Rating for this filter in the five micron size is 100/50, or 2. In other words, the filter bag is said to have a Beta 5 of 2. The efficiency is 50% in the five micron range.

Recommended Clarity Levels Of Filtered Coolant Filtered coolant shall meet or exceed the following average clarity levels.	Average Particle Size	Concentration: PPM
	<b>Ultra Fine:</b> Honing, microsizing, lapping, and polishing	larger than 8 microns between 1 to 8 microns
<b>Very Fine:</b> Grinding, gun-drilling, gun-reaming (with tool diameters of 0.125 inch or less)	larger than 8 microns between 1 to 8 microns	<b>less than 15 micron</b> 10 PPM to 15 PPM 50 PPM to 100 PPM
<b>Fine:</b> Tapping, milling, lathe, hobbing, drilling, boring, general machining	larger than 8 microns between 1 to 8 microns	<b>less than 20 micron</b> 15 PPM to 30 PPM 100 PPM to 200 PPM

Single-Bag Filters

## Model 4 Coolant Filter

For Flows to 5 gpm

Flows can be higher. These flows are selected to optimize dirt holding capacity.

(For more detail information and other specifications concerning the Model 4, please see page 4 or contact a Rosedale representative.)

These rugged and reliable bag filters are tailored to high-capacity applications yet are relatively low in cost, making these durable filtration devices one of the best values on the market. Choose from among the pre-selected ordering codes listed below for filter flows to 5 gpm with a 200 psi rated housing.

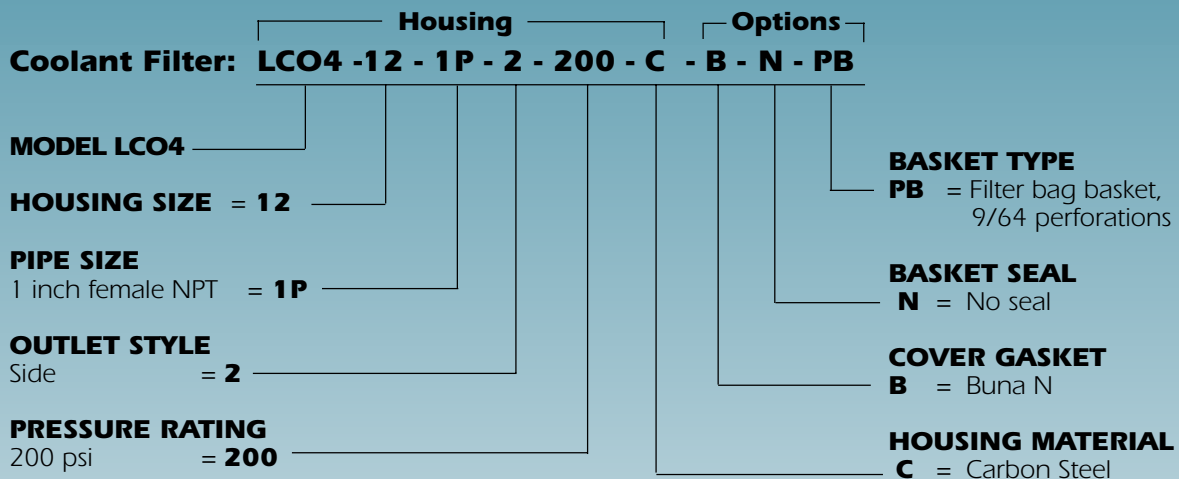

### MODEL 4 SUGGESTED BAG PE 5 P 4 S

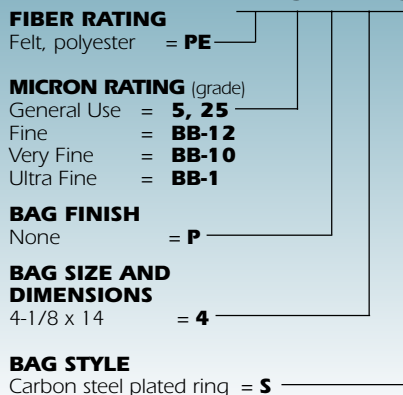

### Technical Specifications

<b>Bag Size:</b>	Any Standard Size 4 Bag
<b>Drain connection:</b>	1" NPT
<b>Piping connections:</b>	1" NPT
<b>Construction material:</b>	Carbon steel
<b>Pressure rating:</b>	200 psi
<b>Weight:</b>	20 lbs
<b>Surface Area:</b>	1 Ft <sup>2</sup>

**Note:** If your application requires options other than those listed, please turn to page 4.

Single-Bag Filters

**Model 8 Coolant Filter**

For Flows to 25 gpm

Flows can be higher. These flows are selected to optimize dirt holding capacity.

(For more detail information and other specifications concerning the LCO Model 8, please see page 17 or contact a Rosedale representative.)

These rugged and reliable bag filters are tailored to high-capacity applications yet are relatively low in cost, making these durable filtration devices one of the best values on the market. Choose from among the pre-selected ordering codes listed below for filter flows to 25 gpm with a 125 psi rated housing.

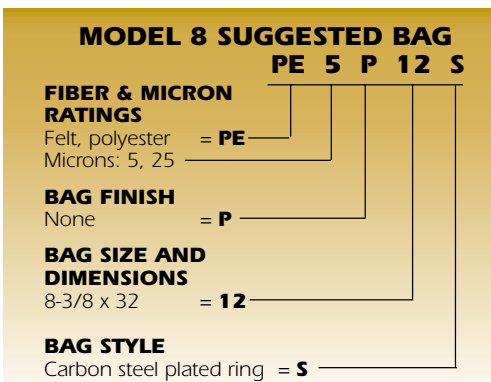
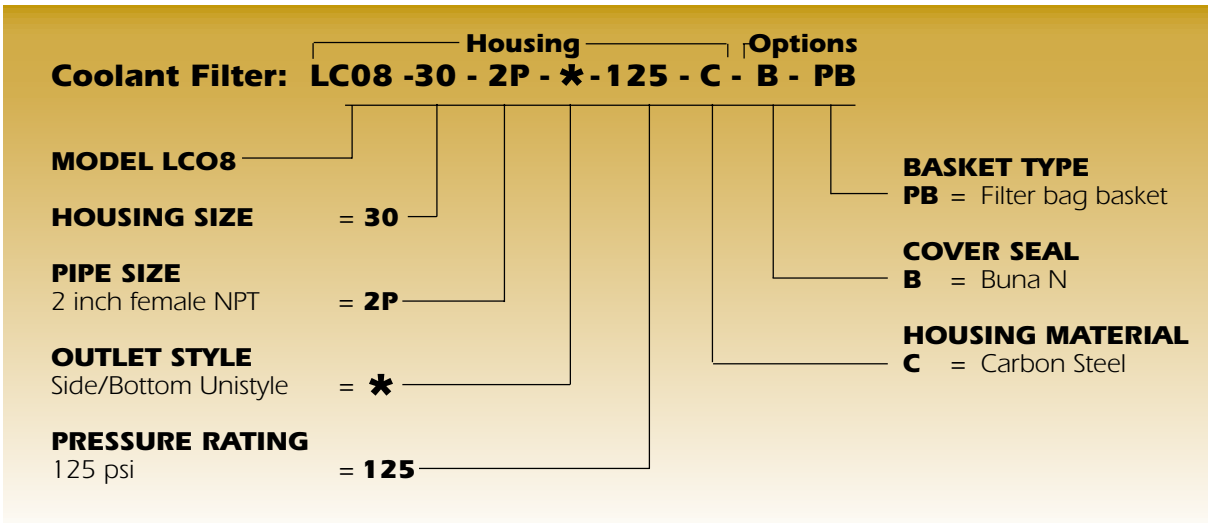

**Technical Specifications**

<b>Bag Size:</b>	Any Standard Size 12 bag
<b>Drain connection:</b>	2" NPT
<b>Piping connections:</b>	2" NPT
<b>Construction Material:</b>	Carbon steel
<b>Pressure rating:</b>	125 psi
<b>Weight:</b>	70 lb
<b>Surface Area:</b>	5.6 Ft. <sup>2</sup>

**Note:** If your application requires options other than those listed, please turn to page 17.

## Features

### Typical Single-Bag Filter Housing

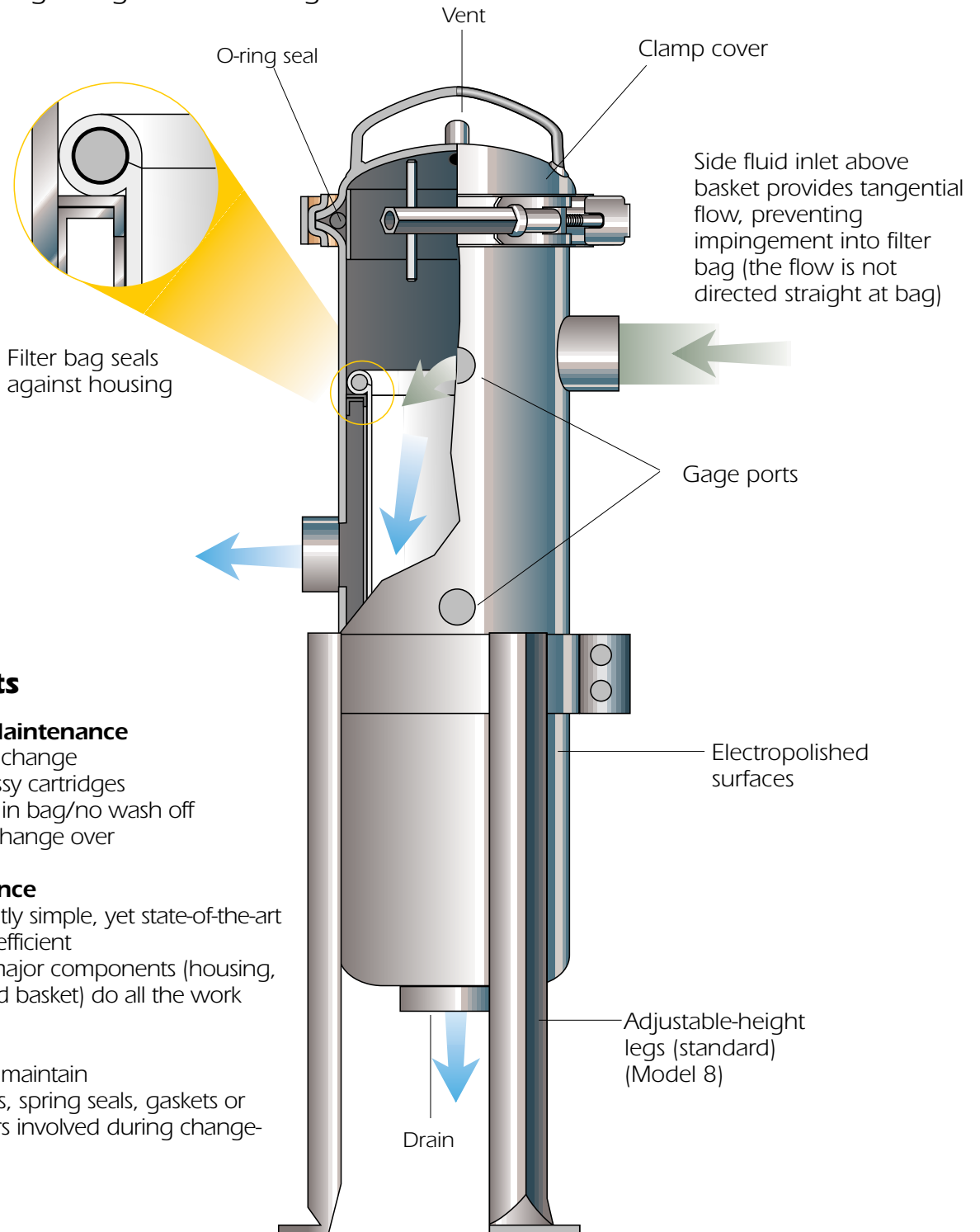

### Benefits

#### Ease of Maintenance

- Easy to change
- No messy cartridges
- Dirt left in bag/no wash off
- Quick change over

#### Performance

- Inherently simple, yet state-of-the-art
- Highly efficient
- Three major components (housing, bag and basket) do all the work

#### Service

- Easy to maintain
- No caps, spring seals, gaskets or adapters involved during change-out

## R Multi-Bag Filters

These multi-bag filters offer the widest range of flow capacities and contaminant holding capabilities. With anywhere from 2–23 perforated stainless-steel baskets specially fitted to hold disposable or cleanable filter bags, these high-capacity multi-bag filtration devices are extremely versatile. Bag sizes meet industry-wide standards: conventional 3-inch baskets take bag size 2 while optional 15-inch basket take bag size 1. The standard pressure rating for all models is 150 psi and all housing units can be supplied with a ASME code stamp, if required.

Choose from among the pre-selected ordering codes listed below. If you need assistance determining the size or type of product that suits your application, call a Rosedale representative today for assistance and information.



**Coolant Filter: 24 - 30 - 4F - 1 - 150 - C - B - N - PB**

<b>Housing</b>		<b>Options</b>	
<b>MODEL NO.</b> Diameter (inches) = <b>Model No.</b>		<b>BASKET TYPE</b> <b>PB</b> = Filter bag basket	
<b>BASKET DEPTH</b> 30 inch (std.) = <b>30</b>		<b>BASKET SEAL</b> <b>N</b> = No seal	
<b>PIPE SIZE</b> (Flanged <sup>1</sup> )		<b>COVER SEAL</b> <b>B</b> = Buna N	
2 in. (models 16, 18) = <b>2F</b>		<b>HOUSING MATERIAL</b> <b>C</b> = Carbon Steel	
3 in. (models 16, 18, 22, 24) = <b>3F</b>			
4 in. (models 16, 18, 22, 24, 30) = <b>4F</b>			
6 in. (models 22, 24, 30, 36) = <b>6F</b>			
8 in. (models 30, 36, 42, 48) = <b>8F</b>			
10 in. (models 36, 42, 48) = <b>10F</b>			
12 in. (models 42, 48) = <b>12F</b>			
<b>OUTLET STYLE</b> In-line, bottom (std.) = <b>1</b>			
<b>PRESSURE RATING<sup>2</sup></b> 150 psi = <b>150</b>			

**MODEL 8 SUGGESTED BAG**  
**PE 5 P 2 S**

**FIBER & MICRON RATINGS**  
Felt, polyester = **PE**  
Microns: 5, 25

**BAG FINISH**  
None = **P**

**BAG SIZE AND DIMENSIONS**  
7-1/16 x 32 = **2**

**BAG STYLE**  
Carbon steel plated ring = **S**

## Features

### Typical Multi-Bag Filter Housing

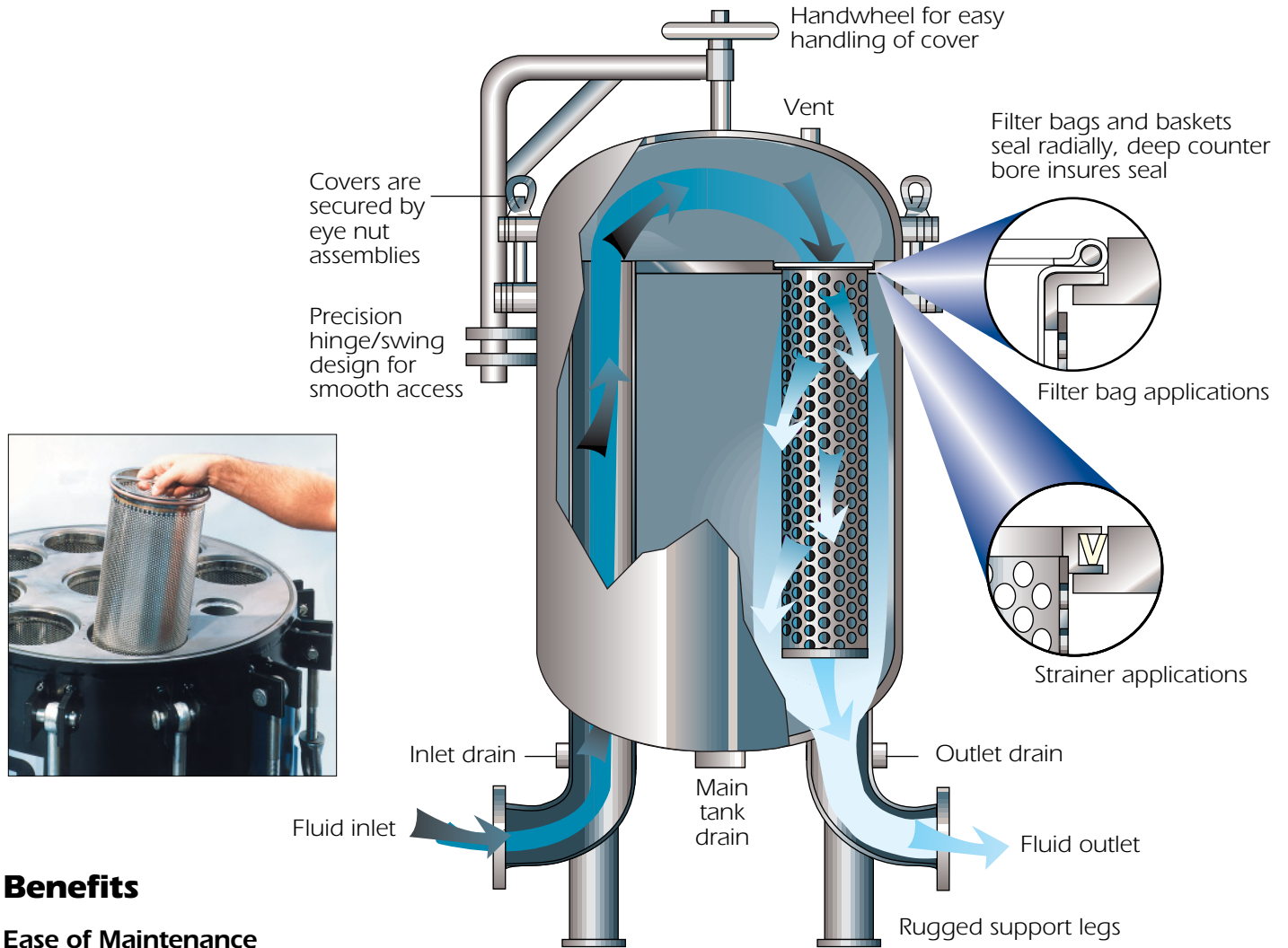

## Benefits

### Ease of Maintenance

- Easy to change
- No messy cartridges
- Dirt left in bag/no wash off
- Quick change over

### Performance

- Inherently simple
- Three major components (housing, bag and basket) do all the work

### Service

- Easy to maintain
- No caps, spring seals, gaskets or adapters involved during change-out

## Model Selection (30-inch deep baskets)

Model No. (and diameter in inches)	Number of Baskets	Straining, Filtering Area (ft <sup>2</sup> )	Standard Pipe Sizes Avail. (in.)	Suggested Flow Rate <sup>3</sup> (gpm)
16	2	8.8	2	50
18	3	13.2	2	75
22	4	17.6	2,3	100
24	6	26.4	3	150
30	8	35.2	4	200
36	12	52.8	4	300
42	17	74.8	6	425
48	23	101.2	6	575

## **R** The Quest For Longer Filter Life

The quest for longer filter life is experiencing renewed interest. Until recently, filters could be easily disposed of when dirty. Now, these spent filters are increasingly being classified as hazardous waste, and their disposal can become a significant budget item very quickly!

Rosedale Products has recently completed a study (for an automotive customer) of filter life and dirt holding capacity. The goal was to reduce the labor needed for cartridge change-out by reducing the frequency of change. There would also be a reduction in the total number of waste cartridges. Our test demonstrated that the amount of contamination being removed increased by ten times. The lower velocity of flow per unit of surface area enables a more thorough loading of the contamination. Surprisingly, this benefit of large surface area is seldom realized because the initial capital expense is higher.

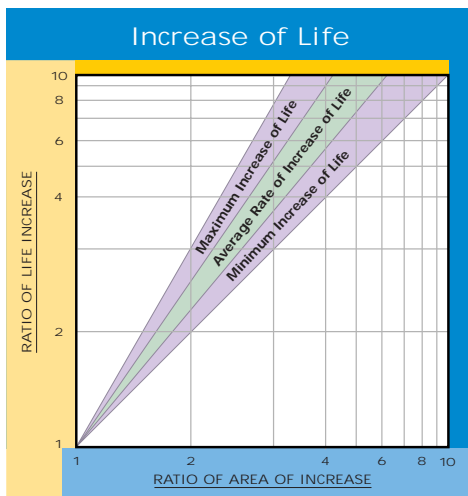

### Choosing the Proper Filter for Sump Cleanup

#### Calculating Beta Rating

In order to calculate the Beta Rating required to perform a cleanup of a sump that has contaminants, a specific formula can be used. The

question of how clean comes down to determining the minimum size (in microns) of the contaminant particles, and the percentage of these particles that must be removed.

#### Relevant factors include the following:

1. Sump size in gallons
2. Pump capacity in gallons per minute (GPM)
3. Length of time allowable for cleanup (in minutes)
4. The degree of cleanliness required (in percentage):
  - 90 percent = 1/10 = .1
  - 95 percent = 1/20 = .05
  - 99 percent = 1/100 = .01
  - 99.9 percent = 1/1000 = .001
5. The corresponding natural logs of cleanliness reduction:
  - ln .1 = -2.3                      ln .01 = -4.6
  - ln .05 = -3.0                    ln .001 = -6.9

### The Cleanup Formula

$$\frac{\frac{Qt}{V}}{Qt + \ln C} = \text{Beta (B)}$$

(selected size)

- Q** = flow rate (in GPM)
- t** = time for cleanup (in minutes)
- V** = volume of tank (in gallons)
- ln** = natural log of C
- C** = concentration in decimal (eg. .05)

### Determining Pump Duration

Also, a formula can be used to calculate how long pumping must continue when the level of cleanliness and the filter element are predetermined. The following problem is provided as an example:

**Example 1:** How much time (t) is required to filter out 95% of 10 micron and larger particles (.05 concentration factor C) using a BB-10 bag if V=100 gallon tank. Q=35 GPM pump, and B<sub>10</sub> for BB-10 is 2?

**Step 1:** 
$$\frac{\frac{Qt}{V}}{\frac{Qt + \ln C}{V}} = B_{10}$$

**Step 2:** 
$$\frac{\frac{35t}{100}}{\frac{35t + (-3)}{100}} = 2$$

**Step 3:** 
$$\begin{aligned} .35t &= (.35t-3)2 \\ .35t &= .70t-6 \\ .35t &= 6 \end{aligned}$$

**Step 4:** 
$$t = 17.14$$

**Observation:** 17.14 minutes x 35 GPM = 506 gallons, or a 5 time turnover.

**Example:** Under the same circumstances, how much time would it take to filter out 99% of the particles microns and larger?

**Step 1:** 
$$\frac{\ln C_t}{C_i} = \ln .01 = 4.6$$

**Step 2:** 
$$\begin{aligned} .35t &= (.35t-4.6)11 \\ .35t &= 3.85t-50.6 \\ .35t &= 50.6 \end{aligned}$$

**Step 3:** 
$$t = 14.5 \text{ minutes}$$

**Observation:** 14.5 minutes x 35 GPM = 506 gallons, or a 5 time turnover.

The calculations for cleanup demonstrate that any filter or bag that has the proper Beta Rating for the particle size that needs removing will be sufficient if the rating for that particle size is over 1.5 (33%).

### Filtering a Sump/Tank to Specific Micron Level

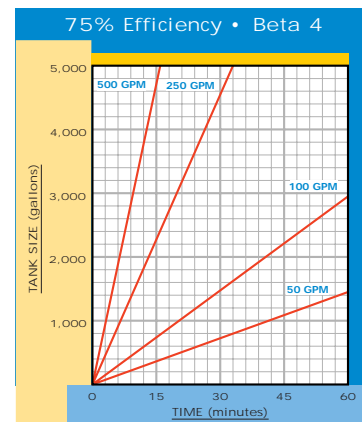
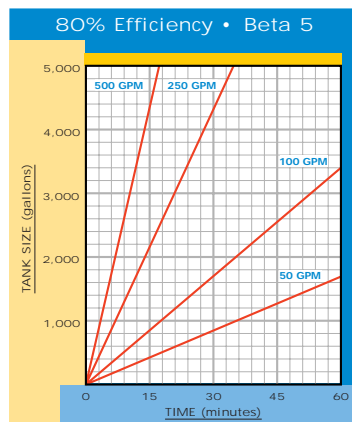
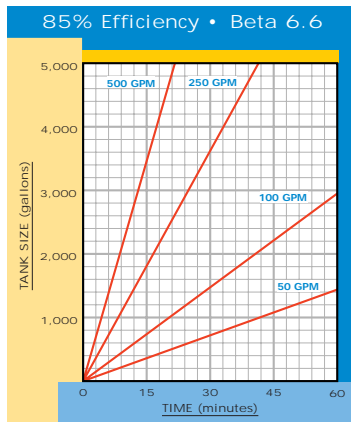
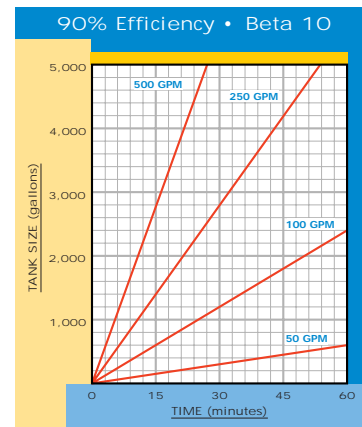
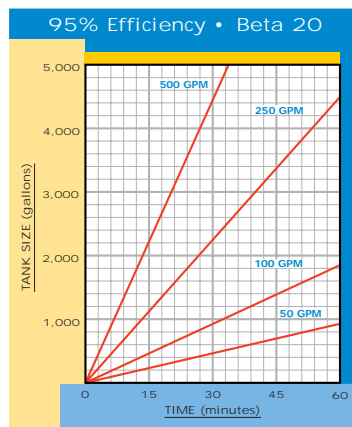
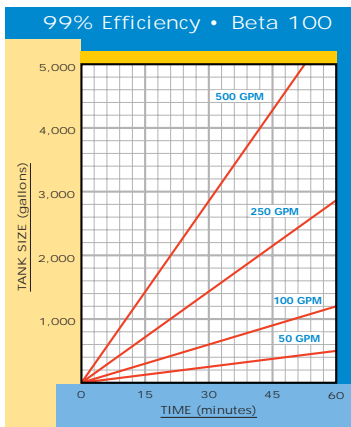

# Beta Rating

Use this chart to determine the filter performance you require. The Product Groups are listed on the left, Micron Sizes are in red, with corresponding Efficiency (blue) and Beta Rating (green) along the top.

EFFICIENCY % BETA RATING	PAGE NO.	30 1.5	50 2	66 3	80 5	90 10	95 20	98 50	98.7 75	98.75 80	99 100	99.8 500	99.9 1000	99.95 2000	99.98 5000	99.99 10000	ELEMENT AREA FT <sup>2</sup>	FLOW RATE GPM*	DIRT HOLDING CAP. (lbs)	
<b>PLATINUM 500</b>																				
PS-520											0.25		<0.5		0.5		85	30 ↕ 50	8	
PS-521	124										0.9		1.4		2				8	
PS-523											1.6		2		5				8	
PS-525												2		6.5		10				10
PS-527												9		17		20				10
PS-528												18		30		40				12
PS-529												40		60		70		12		
<b>PLATINUM 700</b>																				
PS-740											0.25		<0.5		0.5		120	50 ↕ 100	12	
PS-741	126										0.9		1.4		2				15	
PS-743											1.6		2		5				15	
PS-745												2		6.5		10				17
PS-747												9		17		20				18
PS-748												18		30		40				20
PS-749												40		60		70		20		
<b>PLATINUM 900</b>																				
PS-940											0.25		<0.5		0.5		600	200 ↕ 400	55	
PS-941	128										0.9		1.4		2				75	
PS-943											1.6		2		5				75	
PS-945												2		6.5		10				85
PS-947												9		17		20				90
PS-948												18		30		40				100
PS-949												40		60		70		100		
<b>PLEATED HI-E</b>																				
PL-PEMF/POMF-1	130					1	1				2					10	25	35 ↕ 100	1.5	
PL-PEMF/POMF-3							3				5								3	
PL-PEMF/POMF-8							8				19								5	
PL-PEMF/POMF-19							19				25								6	
<b>PLEATED STANDARD</b>																				
PL-PE/PO-35 (1 nom.)	131						35										25	50 ↕	7.5	
PL-PE/PO-48 (5 nom.)							48												8	
PL-PE/PO-55 (10 nom.)							55												9	
PL-PE/PO-70 (25 nom.)							70												10	
PL-PE/PO-90 (50 nom.)							90								150				11	
<b>HI-E</b>																				
PEMF/POMF-1	120					1	1				2					10	4.4 SINGLE LAYER	20 ↕ 50	0.2	
PEMF/POMF-3							3				5								0.25	
PEMF/POMF-8							8				19								0.35	
PEMF/POMF-19							19				25								0.75	
<b>STANDARD</b>																				
PE/PO-1	111			20	30		35										4.4 SINGLE LAYER	50 ↕ 110	0.6	
PE/PO-5			10			30	48	40											0.7	
PE/PO-10			40				55												0.8	
PE/PO-25							70												0.9	
PE/PO-50							90												1	
<b>SURFACEPLUS</b>																				
SP-PE/PO-35	118			20	30		35										13.2 SINGLE LAYER- EXTRA LONG	50 ↕ 110	2.2	
SP-PE/PO-48			10			30	48	40											2.8	
SP-PE/PO-55			40				55												3.2	
SP-PE/PO-70							70												3.63	
SP-PE/PO-90							90												4	
<b>GRADED DENSITY</b>																				
GD-523	131						1				2		20	30		40	4.4 SINGLE LAYER	20 ↕ 50	0.6	
GD-525							3				5								0.65	
GD-527							8				19								1.25	
GD-529							19				25								2	
<b>BETA</b>																				
BB-1	114		1			3	4			8	10						4.4 SINGLE LAYER	20 ↕ 50	0.15	
BB-10			10				16			20									0.35	
BB-12			12				37			47									0.6	
<b>GIARDIA</b>																				
GLR-825	133													3			4.4 TWENTY SIX LAYER	10	0.5	

\*Based on water and nominal flow rate

## Choosing the Proper Filter Bag

The Beta Rating for the cleanup will vary by virtue of the time required to accomplish the cleanup. The following problems and corresponding Beta Ratings and Efficiency Correlations chart will illustrate this fact.

### Beta Ratings & Efficiency Correlations

<b>Beta Rating</b>	2	3	4	5
<b>Efficiency</b>	50%	66%	75%	80%
<b>Beta Rating</b>	10	50	100	1000
<b>Efficiency</b>	90%	98%	99%	99.9%

**Example 1:** Which element might be used to obtain 95% removal (ln of .05 = 3.0) of particles 10 microns and larger from a 100 gallon reservoir (V = 100) using a 10 GPM pump (Q = 10) in 20 minutes (t = 20)?

<b>Step 1:</b>	$B_{10} = \frac{10 \times 20}{100} + (-3.0)$
<b>Step 2:</b>	$B_{10} = \frac{2}{2-3}$
<b>Step 3:</b>	$B_{10} = -2$

**Observation:** A negative value for Beta Rating indicates that 95% particle removal is not possible in 20 minutes.

**Example 2:** In the same situation, which element could be used if the cleanup time were increased to 60 minutes (t = 60)?

**Example 3:** Is this cleanup possible if the time were compromised to 40 minutes? If so, which element?

## Filtering Continuous Loads with Dirt Ingression

The challenge is to maintain a process liquid cleanliness of some maximum parts per million, given that the system flow rate is established at a given gallons per minute with dirt being introduced at a rate of X PPM.

The graphs on this page will help to determine the number of filters and filtration flow rate required as well as the filter efficiency necessary to maintain the process liquid to a specified level.

**Example 1:** A coolant system which flows from a coolant tank to a bank of grinders at a flow rate of 500 gallons per minute picks up 10 ppm from the grinders, making the tank so dirty that the coolant flowing into the machines must be changed. The customer wants to maintain the coolant purity to a maximum 40 PPM. The customer has stated the ppm contaminants are larger than 5 micron.

**A –** Referring to our Beta Ratings Chart on page 85 you will see that we have several bag filters capable of filtering 5 micron dirt.

However, the efficiencies vary. If you were to choose a BB-1 filter, you would attain 95% efficiency at 5 micron.

- B –** Go to the Continuous Dirt Load Graphs below and find the graph for Filter Efficiency = 95%.
- C –** Look down the left side of the graph to locate the maximum dirt load desired (40 PPM) and follow the line to right to the intersection of PPM introduced by the process (10 PPM).
- D –** Moving straight down the graph from this intersection point you will note that the element must filter at a rate equal to 20% of the process flow rate of 500 GPM.

**Observation:** If the filtering proceeds at 100 GPM with the BB-1 bag, the process dirt load will be maintained at 40 PPM. **Note:** A less efficient bag could be used if the filter flow rate were increased. Choosing the PL-PEMFL-P2 bag will require that the flow rate be 140 GPM to maintain the dirt load at 40 PPM.

## Continuous Dirt Load Graphs

