

## Solids/Liquids Separators

### In-Line Separators for Industrial Applications

Use our centrifugal-action separator to remove grit, sand, metal chips, fines, and other solids from liquids. Perfect for use as a pre-filter to extend the life of fine filtration systems. These units require little or no maintenance, as there are no moving parts to fail or wear out, or filter media to clean or replace. The unit only requires a simple purging, eliminating downtime due to cleaning or backwashing. For flows from 6 gpm and retention ratings to 50 micron.



### Features

- Low constant pressure drops
- Piped housings
- Carbon steel or stainless steel (304 or 316) construction for housings
- All housings are electropolished to resist adhesion of dirt and scale
- ASME code stamp available
- Pipe sizes 3/8 through 6-inch (larger sizes also available)

### Options

- Different outlet connections
- Special materials

### Typical Applications

- Cooling towers
- Process water
- Food processing
- Chemical processing
- Well water
- Pulp & paper mills
- Mining operations
- Steel mills
- Petrochemical industry
- Power plants
- Protection of spray nozzles and other small orifices
- Chip removal from cutting coolants
- Car and vehicle wash systems
- Paint spray booths
- Heat exchangers
- Spray nozzle protection
- Industrial laundries
- Solids recovery
- Parts washing systems
- Pump protection
- Domestic Water
- Recirculating cooling water
- Sprinkler systems
- Quench water
- Pre-filter for seawater

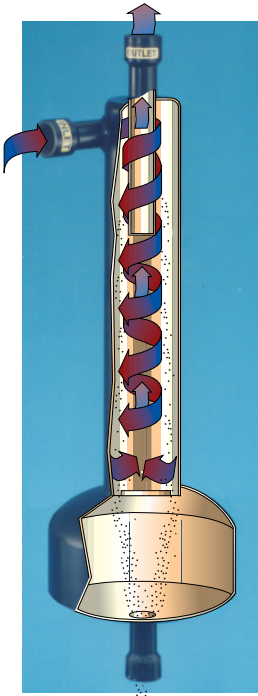

**How it works:**  
 Fluid enters the pressure vessel tangentially at high velocity. A centrifugal action is created, which forces the solids to separate and enter the sump, while the clean liquid exits up through the standpipe. The solids collect in the sump, and can easily be purged. The operation is so simple, it can be set to automatically purge on a timed interval.

**Separator Performance Chart**

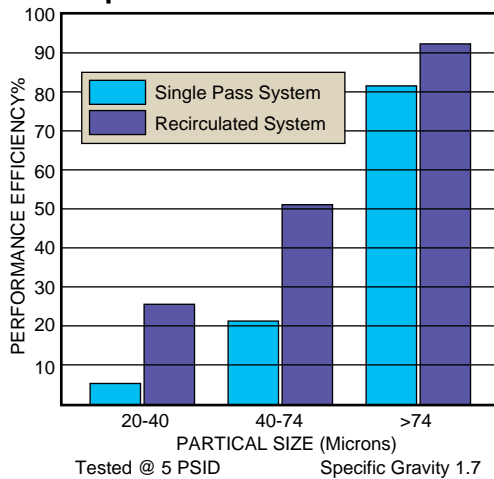

**Specific Gravity of Various Materials**

Material	Specific Gravity
Aluminum	2.7
Ashes (Coal)	2.0
Brass	9.0
Bronze/Copper	8.9
Carbon/Concrete/Lava	1.8-2.5
Coal (Anthracite)	1.3-1.9
Earth (Silt/Soil)	1.2-2.0
Glass (Crystal)	3.0
Granite/Gravel	2.5-3.0
Graphite	2.3
Iron	7.8
Lead	11.3
Limestone	2.8
Manganese	7.4
Nickel	8.9
Sand/Silica/Shale	2.6-2.8
Steel	7.8
Tin Ore	6.4-7.0

**FLOW RANGE – GPM**

Model No.	Pipe Size (inch)	5 PSID	10 PSID	CV Factor	Solids Cap.
SEP-6	3/8	3	6	1.8	.24 gal.
SEP-11	1/2	7	11	3.4	.24 gal.
SEP-25	3/4	15	25	2.5	.94 gal.
SEP-40	1	30	40	14	.94 gal.
SEP-75	1-1/4	55	75	25	.9 gal.
SEP-80	1-1/2	60	80	25	.9 gal.
SEP-130	2	90	130	41	.87 gal.
SEP-140	2-1/2	96	140	41	.87 gal.
SEP-275	3	200	275	85	1.04 gal.
SEP-553	4	425	553	175	7.81 gal.
SEP-1265	6	985	1265	400	16.26 gal.

Model Number	Pipe Size (inch)	Inlet/Outlet	Drain Size (inch)
SEP-6	3/8	NPT	1
SEP-11	1/2	NPT	1
SEP-25	3/4	NPT	1
SEP-40	1	NPT	1
SEP-75	1-1/4	NPT	1
SEP-80	1-1/2	NPT	1
SEP-130	2	NPT	1
SEP-140	2-1/2	NPT	1
SEP-275	3	NPT or Flanged	1
SEP-553	4	Flanged	2
SEP-1265	6	Flanged	2

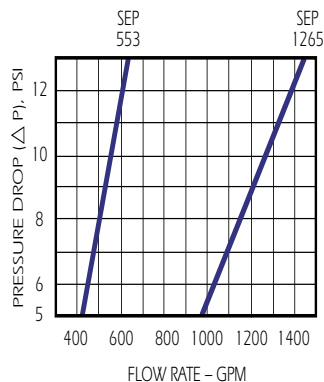
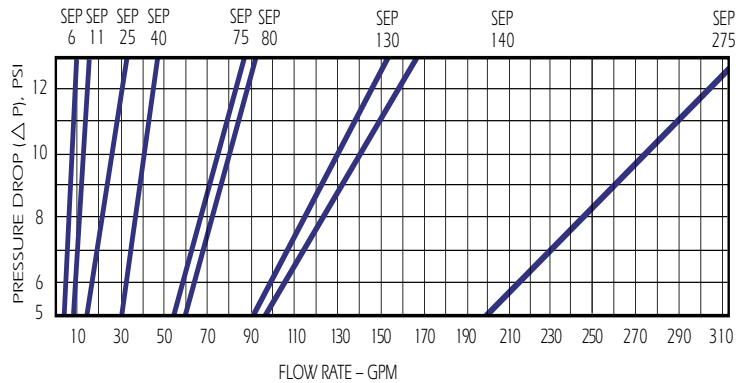

**Separator Sizing:**

Separators are generally sized so that there is at least a 5 PSID pressure drop across the unit. Separation efficiency increases as pressure drop increases. We've shown flow ranges for each unit based on 5 and 10 PSID. Choose a unit based on a flow/efficiency balance.

### Installation

The Separator should be installed in a near vertical position. The unit should be supported by means other than the inlet/outlet piping. First, connect the outlet of the unit to the outlet piping. Then install any supports, such as U-bolts or legs. Next, connect the inlet piping to the inlet. Test for leaks and separation. The unit is now ready for operation.

### Purging and Maintenance

Separators must be purged regularly. If they are not, the separated solids will accumulate and overflow the collection area, affecting performance and contaminating effluent.

You can manually, automatically, or continuously purge the collection area of the separator. Manual purging requires that the operator open a simple valve and empty the contents. Automatic purging can be done many different ways, but the simplest is setting a timer to open and close the valve, purging the contaminant on a regular basis. Continuous purging simply requires leaving a manual valve partially open at all time, letting the contaminant leak out at a controlled rate. For best results, all purging should be done while the separator is in operation. Avoid purging "uphill" which will result in buildup and clogging, affecting performance and operation.

Simple rules of maintenance include checking the purge valve regularly for clogging, scale, and buildup. If the unit is installed in an area where the ambient temperature is below freezing, the collection area and all purge piping should be kept from freezing while operating. If left in idle state under

### Dimensions (IN)

Model	A	B	C	D	E
SEP-6	3.0	14.8	4.5	1.9	.6
SEP-11	3.0	14.8	4.5	1.9	.6
SEP-25	4.5	17.2	8.6	3.5	1.1
SEP-40	4.5	23.6	8.6	3.5	1.1
SEP-75	4.5	23.5	8.6	4.5	1.4
SEP-80	4.5	23.5	8.6	4.5	1.3
SEP-130 (2")	4.8	22.6	8.6	6.6	2.1
SEP-140 (2.5")	6	22.6	8.6	6.6	1.9
SEP-275	6.6	25.2	10.7	8.6	2.6
SEP-553	13.	45.2	18.0	12.7	4.1
SEP-1265	16.4	58.0	24.0	16.0	4.7

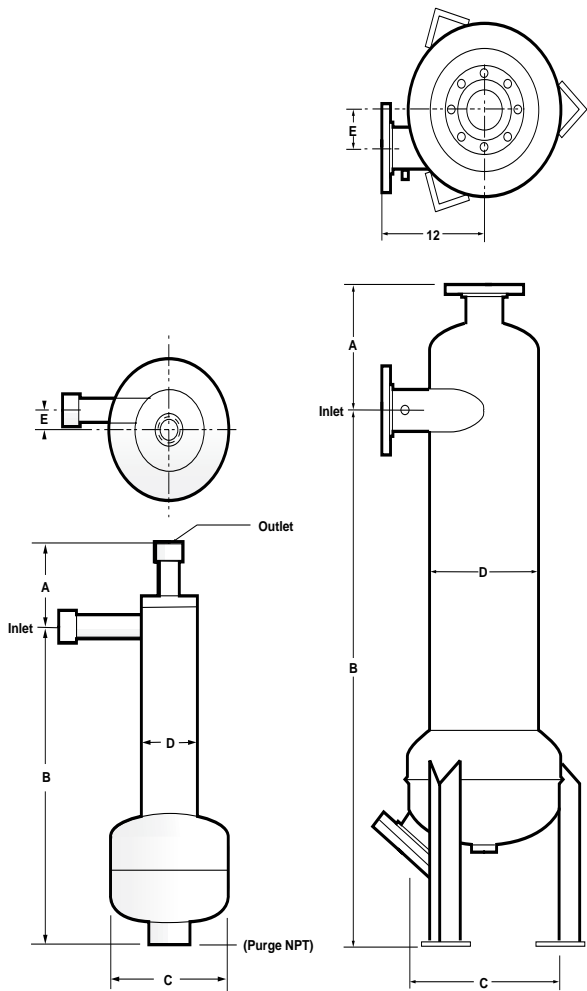

SEP-6 through SEP-275

SEP-553 and SEP-1265



## How To Order

Build an ordering code as shown in the example

Example:		SEP-275-3P-150-C-C-APV		Options
<b>Model No. and Flow Rate</b>				<b>Option</b>
6 GPM = <b>SEP-6</b>				<b>APV</b> = Optional APV Automatic
11 GPM = <b>SEP-11</b>				<b>P</b> = Manual purge valve
25 GPM = <b>SEP-25</b>				Leave blank for no purge valve
40 GPM = <b>SEP-40</b>				<b>ASME Code Stamp</b>
75 GPM = <b>SEP-75</b>				<b>C</b> = Code
80 GPM = <b>SEP-80</b>				<b>Housing Material</b>
130 GPM = <b>SEP-130</b>				<b>C</b> = Carbon Steel
140 GPM = <b>SEP-140</b>				<b>S</b> = 304 Stainless Steel
275 GPM = <b>SEP-275</b>				<b>S316</b> = 316 Stainless Steel
553 GPM = <b>SEP-553</b>				<b>Pressure Rating</b> <sup>2</sup>
1265 GPM = <b>SEP-1265</b>				<b>150</b> = 150 PSI (NPT or Flanged)
<b>Pipe Size, NPT, Flanged</b> <sup>1</sup>				
3/8-inch NPT = <b>3/8P</b> (SEP Model 6)				
1/2-inch NPT = <b>1/2P</b> (SEP Model 11)				
3/4-inch NPT = <b>3/4P</b> (SEP Model 25)				
1-inch NPT = <b>1P</b> (SEP Model 40)				
1-1/4-inch NPT = <b>1-1/4P</b> (SEP Model 75)				
1-1/2-inch NPT = <b>1-1/2P</b> (SEP Model 80)				
2-inch NPT = <b>2P</b> (SEP Model 130)				
2-1/2-inch NPT = <b>2-1/2P</b> (SEP Model 140)				
3-inch NPT = <b>3P</b> (SEP Model 275)				
3-inch Flanged = <b>3F</b> (SEP Model 275)				
4-inch Flanged = <b>4F</b> (SEP Model 553)				
6-inch Flanged = <b>6F</b> (SEP Model 1265)				

**NOTE:**

- Flanges provided with the housing match the pressure rating of the vessel. Housings rated 150 psi have 150 class flanges. ANSI B16.5 Pressure-Temperature rating tables determine flange class for ASME code housings. Consult factory.
- Higher pressure ratings are available. Consult factory.